

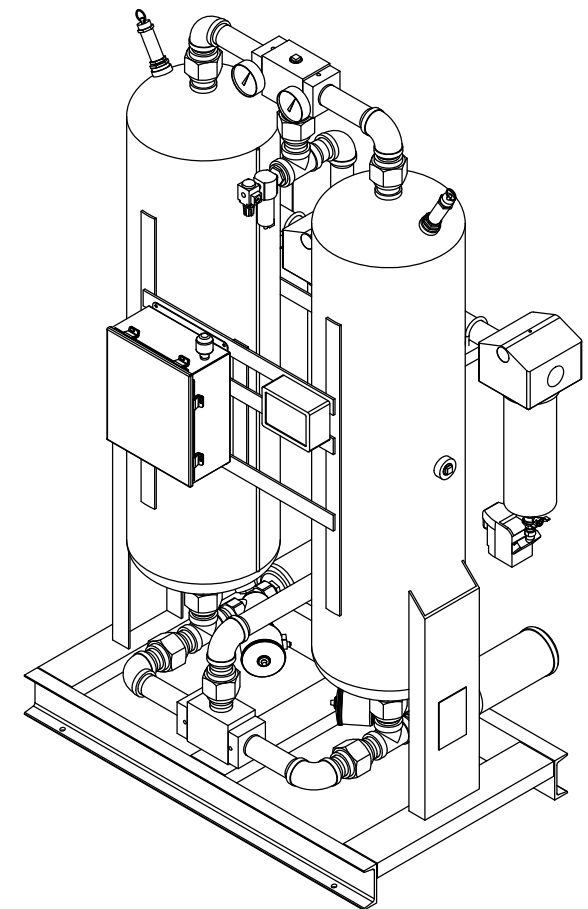

ITEM NO	QTY	DESCRIPTION
1	2	DESICCANT VESSEL
2	1	INLET SHUTTLE VALVE
3	1	OUTLET SHUTTLE VALVE
4	2	PURGE EXHAUST VALVE
5	2	EXHAUST MUFFLER
6	2	PRESSURE GAUGE
7	2	PRESSURE RELIEF VALVE
8	1	ELECTRICAL ENCLOSURE
9	1	CARBON MONOXIDE MONITOR
10	1	PRE-FILTER
11	1	ACTIVATED CARBON FILTER
12	1	AFTER FILTER
13	1	ZERO-LOSS DRAIN



UNLESS OTHERWISE SPECIFIED:		NAME	DATE	 <b>COMPRESSED AIR AND GAS PRODUCTS</b> 323 CRISP CIRCLE MARYVILLE TENNESSEE 37801 PHONE: 865-681-7066 FAX: 865-681-7069
DIMENSIONS ARE IN INCHES TOLERANCES: FRACTIONAL ± 0.125 ANGULAR: ± 0.5° TWO PLACE DECIMAL ± .03 THREE PLACE DECIMAL ± .003		DRAWN	TF	
MATERIAL		CHECKED	MS	2/21/12
FINISH		ENG APPR.		
DO NOT SCALE DRAWING		MFG APPR.		
		Q.A.		
		COMMENTS:		TITLE: <b>DRYER, DESICC, BHD-500 STD ASSY; 150 PSIG, 100 DEG F, T-16, REV 1</b>
		SIZE	DWG. NO.	
		<b>B</b>	AG9978240	
		SCALE: 1:12	WEIGHT:	SHEET 1 OF 1

**PROPRIETARY AND CONFIDENTIAL**  
 THE INFORMATION CONTAINED IN THIS DRAWING IS THE SOLE PROPERTY OF AIRCEL LLC. ANY REPRODUCTION IN PART OR AS A WHOLE WITHOUT THE WRITTEN PERMISSION OF AIRCEL LLC IS PROHIBITED.